



Cat[®] Trenchers

SKID STEER LOADERS
MULTI TERRAIN LOADERS

Cat[®] Trenchers are designed for cutting narrow straight trenches in the soil prior to laying electrical, telephone and cable lines, or water and gas pipe. Trenchers are ideal for residential, commercial, agricultural, building construction, lawn care and golf course maintenance.

FEATURES:

Direct drive system

- Direct drive system features a variable speed, bi-directional, gerotor style motor that delivers optimal chain speed, chain pull and torque for maximum trenching performance in a broad range of soil types.

Durable double standard antibackflex chain

- Durable double standard antibackflex chain eliminates chain backlash and ensures teeth are positioned at the most efficient angle for smooth cutting and longer tooth life.

Hardfaced, tungsten carbide steel cupped teeth

- Hardfaced, tungsten carbide steel cupped teeth are standard for long life in many soil conditions. Teeth are spaced for optimum digging performance in most soil.

Standard boom length

- Standard boom length is used for all-purpose performance. Replaceable weld-on wear strips extend boom life.

Large diameter bolt-on spoil auger

- Large diameter bolt-on spoil auger improves loose soil removal from trenching area and allows for quick, easy removal and servicing.

Hydraulic or manual side-shift

- Hydraulic or manual side-shift on the T6B and T9B provides close trenching flexibility near structures or obstructions. Hydraulic side-shift on the T15B is controlled from the operator's compartment using the standard flow auxiliary hydraulic circuit selector control.

Formed skid shoe

- Formed skid shoe acts as a pivot point and maintains proper spoil auger orientation.

Optional chain types and cutting widths

- Optional chain types and cutting widths are available for specific soil, digging requirements and trench widths.

Optional bolt-on crumber bar with shoe

- Optional bolt-on crumber bar with shoe improves soil removal to provide cleaner trench. Shoes available in size range to accommodate trench width.

Cat XT[™] and medium pressure hose, couplings and O-ring face seals

- Cat XT and medium pressure hose, couplings and O-ring face seals provide superior, leak-free performance and reliability. All hoses are wrapped with nylon woven cordura sleeving for added operator protection. Hydraulic quick disconnects enable fast tool changes.

Quick coupler

- Rugged, opposing edge design holds the work tool securely and allows the operator to quickly change from one high performance Cat Work Tool to another.

Compatibility

Model	Machines
T6B	216B, 226B, 232B, 236B, 242B, 247B, 252B, 257B, 246C, 256C, 262C, 272C, 277C, 287C, 297C
T9B	216B, 226B, 232B, 236B, 242B, 247B, 252B, 257B, 246C, 256C, 262C, 272C, 277C, 287C, 297C
T15B*	226B, 242B, 257B, 246C, 256C, 262C, 272C, 277C, 287C, 297C

* Requires high flow and high flow XPS option on machine.

Cat Trenchers

Specifications

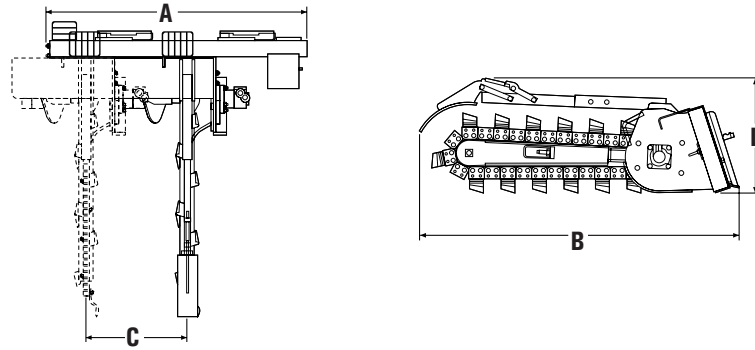

		T6B		T9B		T15B	
A Overall width	mm (in)	1426	(56)	1901	(74.8)	1901	(74.8)
B Overall length	mm (in)	2348	(92)	2705	(106.5)	3010	(118.5)
C Side-shift travel	mm (in)	419	(16.5)	559	(22)	559	(22)
D Overall height	mm (in)	786	(30.9)	786	(30.9)	786	(30.9)
Max auger clearance	mm (in)	534	(21)	534	(21)	534	(21)
Spoil auger diameter	mm (in)	457	(18)	457	(18)	457	(18)
Standard boom length	mm (in)	914	(36)	1219	(48)	1524	(60)
Unit weight	kg (lb)	397	(875)	551	(1,215*)	601	(1,325**)
Required hydraulic flow range	L/min (gpm)	42-83	(11-22)	42-83	(11-22)	95-152	(25-40)
Optimal hydraulic pressure range	bar (psi)	145-227	(2100-3300)	145-227	(2100-3300)	207-310	(3000-4500)
Motor size	cm ³ (in ³)	393.9	(24.0)	393.9	(24.0)	629.1	(38.4)
Theoretical drive shaft torque ¹	N•m (lb•ft)	1447	(1068)	1447	(1068)	2905	(2144)
Chain pull @ max pressure ²	kg (lb)	1207	(2661)	1207	(2661)	2424	(5344)
Chain speed @ max flow ²	mpm (fpm)	155	(508.5)	155	(508.5)	158	(518.3)
Drive shaft speed @ max flow ²	rpm	203		203		207	
Optional cutting widths	mm (in)	152, 203, 254, 305		152, 203, 254, 305		152, 203, 254, 305	
		(6, 8, 10, 12)		(6, 8, 10, 12)		(6, 8, 10, 12)	

* T9B equipped with 1219 mm (48 in) boom, hydraulic side shift control, double standard antibackflex chain, 203 mm (8 in) cutting width, 50/50 combo carbide/cup chain.

** T15B equipped with 1524 mm (60 in) boom, double standard antibackflex chain, 203 mm (8 in) cutting width, 50/50 combo carbide/cup chain.

1 Max. Pressure: T9B – 230 bar (3335 psi), T15B – 290 bar (4205 psi)

2 Max. Flow: T9B – 80 L/min (21 gpm), T15B – 130 L/min (34 gpm)

For more complete information on Cat products, dealer services, and industry solutions, visit us on the web at www.cat.com

AEHQ5836 (11-06)

© 2006 Caterpillar
All Rights Reserved
Printed in U.S.A.

Replaces AEHQ5575-01

Materials and specifications are subject to change without notice. Featured machines in photos may include additional equipment. See your Caterpillar dealer for available options.

CAT, CATERPILLAR, their respective logos, "Caterpillar Yellow," and the POWER EDGE trade dress, as well as corporate and product identity used herein, are trademarks of Caterpillar and may not be used without permission.

CATERPILLAR[®]