

PC203, PC204, PC205, PC206, PC210

Cold Planers for Skid Steer and Multi Terrain Loaders



Hydraulically driven rotating drum with teeth removes a layer of asphalt or concrete prior to resurfacing, used by road repair contractors in restricted areas that cannot be accessed by larger machines and for small municipal road repair works.

Features

- Self-levelling
- Spring and hydraulic tilt
- Independent depth control
- Hydraulic side-shift
- Rotating conical cutting tip

Benefits

- Ensures a constant planing depth when used at any coupler angle incline.
- Enables the unit to oscillate ± 8 degrees in either direction.
- Maximum depths ranging from between 130-200mm can be easily adjusted independently, to allow for multiple pass planning.
- Allows close planing to walls and other jobsite obstructions.
- Inter changeable to ensure even wear, for longer life.

PC203, PC204, PC205, PC206, PC210 Cold Planers

Specifications and Dimensions

		PC203	PC204	PC205	PC206	PC210
A Overall Width	mm	1720	1720	1720	1720	1720
B Maximum Drum width	mm	350	450	450	600	1000
C Length	mm	1180	1180	1180	1265	1130
D Width	mm	840	840	990	930	890
Weight	kg	650	690	750	906	1080
Drive Method		Direct	Direct	Planetary	Planetary	Planetary
Required Hydraulic Flow Range	L/min	55-100	55-100	80-125	95-140	95-180
Optimal Hydraulic Pressure Range	bar	160-240	160-240	160-300	160-300	160-300
Drum Torque at Max Pressure	Nm	1250	1250	2670	3720	5340
Drum Speed at Max Flow	rpm	202	202	220	160	173
Bit Speed at Max Flow	mpm	301	301	336	266	368
Conical Bits (per drum width)		42	42	48	60	78
Standard Bit Type: All Purpose						
Optional Bit Type: Concrete						
Tilt angle range		±8°	±8°	±8°	±8°	±8°
Sideshift Travel	mm	650	650	650	650	465
Maximum Depth of Cut (standard drum)	mm	150	150	150	170	130
Optional Drum Widths/Depths						
PC203: 80/200, 152/200, 203/200, 305/200 mm						
PC204: 80/200, 152/200, 203/200, 305/200, 350/200, 400/150, 450/150, *450/150 mm						
PC205: 80/200, 152/200, 203/200, 305/200, 350/200, 400/200, 450/150, *450/150 mm						
PC206: 80/200, 152/200, 203/200, 305/200, 350/200, 400/150, 450/150, *450/150, 600/170, *600/170 mm						

* Concrete

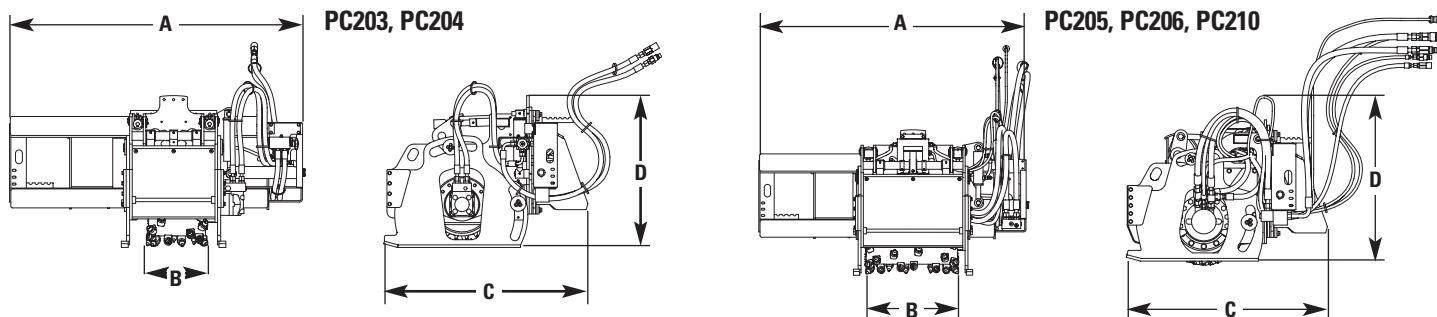

Hydraulic Requirements

PC203/PC204 – Standard flow hydraulics and no electrics. PC205/PC206/PC210 – High flow hydraulics, full electrics.

Matching Guide

Cold Planers	Skid Steer Loaders	Multi Terrain Loaders
PC203	216B, 226B, 232B, 242B, 242B, 236B, 246C, 256C, 262C, 272C	247B, 257B, 277C, 287C, 297C
PC204	226B, 232B, 242B	247B, 257B
PC205	226B HF, 242B HF, 246C, 256C, 262C, 272C	257B HF, 277C, 287C, 297C
PC206	226B HF, 242B HF, 246C, 256C, 262C, 272C	257B HF, 277C, 287C, 297C
PC210	256C, 262C, 272C	277C, 287C, 297C

For more complete information on Cat products, dealer services, and industry solutions, visit us on the web at www.cat.com

HEHX3173-2 (03/2007) hr

© 2007 Caterpillar -- All Rights Reserved

Materials and specifications are subject to change without notice. Featured machines in photos may include additional equipment. See your Caterpillar dealer for available options.

CAT, CATERPILLAR, their respective logos, "Caterpillar Yellow" and the POWER EDGE™ trade dress, as well as corporate and product identity used herein, are trademarks of Caterpillar and may not be used without permission.

CATERPILLAR[®]
TODAY'S WORK. TOMORROW'S WORLD.™