

CVP16, CVP40, CVP75, CVP110

Vibratory Plate Compactors for Hydraulic Excavators



Features

Integral pressure/flow control

Protected hydraulics

Tough and reliable

Optional backfill blade

Cat compactors
for Cat machines

Benefits

Every Cat® compactor includes a pressure/flow control valve as standard. The valve protects the compactor from damaging pressures and flows, enhancing reliability.

All hydraulic hoses are protected inside the frame of the compactor, avoiding most sources of hydraulic hose damage.

Cat quality components and design features ensure reliability in the most adverse working conditions. Cat shaft bearings are lubricated with a continual oil bath.

An optional bolt-on backfill blade allows the compactor to easily push loose material into place, for very fast work when backfilling trenches.

Cat compactors are performance-matched to Cat machines, and integrate perfectly with the Cat hammer line – brackets and hydraulic kits are fully interchangeable between hammers and compactors.

CATERPILLAR®

CVP16, CVP40, CVP75, CVP110 Vibratory Plate Compactors

Specifications and Dimensions

		CVP16	CVP40	CVP75	CVP110
Weight without bracket or blade	kg	215	401	801	1052
Impulse Force	kN	16	40	75	110
Impact Frequency	blows/min	2200	2200	2200	2200
Plate Dimensions	mm	305 x 610	584 x 965	737 x 1090	864 x 1194
Plate Area	m ²	0.195	0.567	0.799	1.031
Height	mm	571	622	770	851
Width	mm	305	584	737	864
Base Plate Pressure	bar	0.88	0.70	0.92	1.06
Machine Requirements					
Carrier Weight	kg	1680-9110	4540-11 340	7260-19 050	13 610-34 020
Flow	lpm	38-45	68-83	106-121	144-159
Pressure	bar	110-172	124-152	138-172	138-172

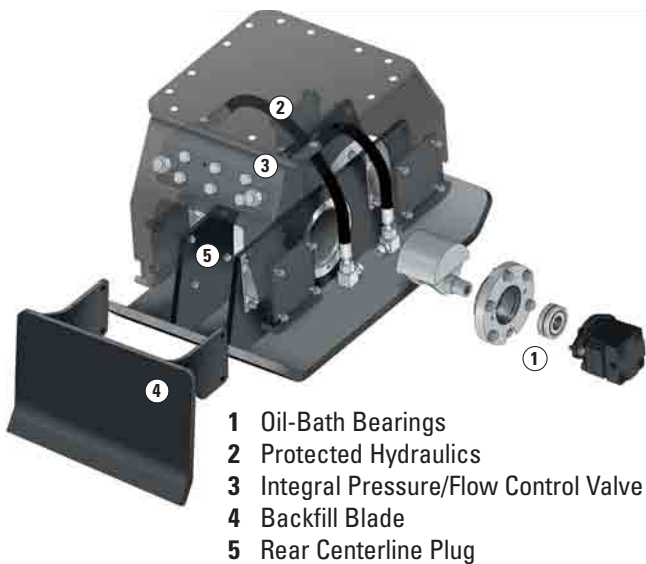

- 1 Oil-Bath Bearings
- 2 Protected Hydraulics
- 3 Integral Pressure/Flow Control Valve
- 4 Backfill Blade
- 5 Rear Centerline Plug

Hydraulic Requirements

Single action tool control, high pressure lines.

Matching Guide

Compactors	Hydraulic Excavators
CVP16	302.5C, 303C CR, 304C CR, 305C CR
CVP40	307C, 308C CR
CVP75	311C, 312C, 314C, 315C, 318C, 319C/319D, M313C/M313D, M315C/M315D, M316C/M316D, M318C/M318D
CVP110	320C/320D, 321C/321D, 322C, 323D, 324D, 325C/325D, 330C/330D, M322C/M322D

For more complete information on Cat products, dealer services, and industry solutions, visit us on the web at www.cat.com

HEHX3146-3 (02/2007) hr

© 2007 Caterpillar -- All Rights Reserved

Materials and specifications are subject to change without notice. Featured machines in photos may include additional equipment. See your Caterpillar dealer for available options.

CAT, CATERPILLAR, their respective logos, "Caterpillar Yellow" and the POWER EDGE™ trade dress, as well as corporate and product identity used herein, are trademarks of Caterpillar and may not be used without permission.

CATERPILLAR[®]
TODAY'S WORK. TOMORROW'S WORLD.™